

Digital UV **NC-UL600** Inkjet Printer

Skillful and Refined Super Height UV Flatbed Printer

come and challenge its printing limit!

NEW



Authorised Distributor

DIGITAL STAR QATAR
ديجيتال ستار قطر

Source of Digital Solutions...

Digital Star Qatar has been leading the digital scene in Doha for over 10 years, as suppliers and distributors of signage, advertising and LED solutions. Our commitment to providing the best quality machinery and top-notch technology from around the world has enabled us to set new and improved standards in sign and digital printing industries. DSQ has developed into a true trendsetter and a reliable destination for customers seeking exhaustive custom and wholesale solutions. From sign makers, digital print houses, POS/POP makers, retail fit-out companies, to exhibition stand builders, construction companies and glass and aluminum fabricators industries, we promise to take your business to unprecedented levels

UV Printing Machine
NC-UL600



A UV inkjet printer uses a UV digital printing process to apply a 2D digital image to a 3D object. A digital inkjet printer propels tiny droplets of ink onto paper, plastic, glass, metal, and other substrates in order to form an image through the use of an ink delivery system, also known as a print head. The image is sent to the printer digitally and is an exact representation of the digital image. The digital UV inkjet printers are mainly used in home appliances, sports products, household goods, and luggage.

ADVANTAGES

- 2400dpi high-precision printing, delicate picture quality.
- The digital UV inkjet printer can achieve 13mm high drop printing
- White color varnish print at the same time in flatbed, 3D relief printing
- Three height levels of the table, 200mm height each level, print height 600mm
- The UV digital inkjet printer is suitable for the luggage industry, household products industry, sporting goods industry, home appliance industry, and other industries



High resolution



high speed



Intelligent



easy operate



small volume



British imported **XAAR 1201** print head. High precision, strong jetting force, stable performance.



Standard scale printing platform. The digital inkjet printer is made of aluminum plate material, internal honeycomb structure, not easy to deform, high flatness

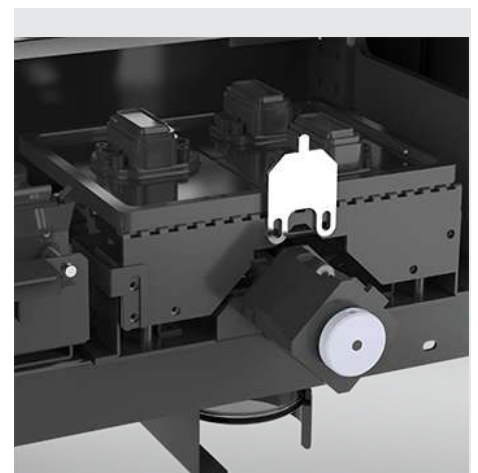

Lifting ink station design. Driven by motor, accurately control the position, intelligently protect the print head

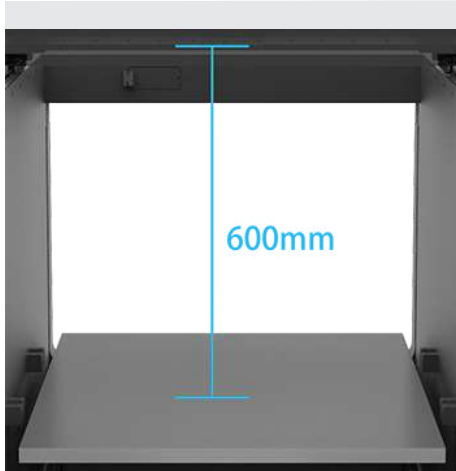

600mm print height.
Support 600mm height printing to meet the printing needs of different product thicknesses



Independent flash tank.
Exclusive design on the left side for easy cleaning of flash ink waste.



Intelligent ink supply system.
With ink stirring, filter, & ink volume alarm functions to ensure smooth ink supply.

APPLICATION FIELD



Handicraft Industry Arrings, Bookmarks, Rubik's Cube, Bowling Balls, Fridge Magnets, Brooches, Buttons, Keychains, Pendants, Small Badges, Small Metal Billboard, Bottle Openers etc.,



Electronics Digital Industry Watches, U Disks, Earphones, Mobile power Banks, Mobile Phone Cases, Tempered Film, Small Speakers, Power Cords, Watches, Mice, Electronic Cigarettes etc.,



Stationery Industry Ballpoint Pen, Glasses Case, Notebook, Pencil case, Ruler, Eraser, Glasses Case Correction Fluid, Mouse Pad, Stapler, Pencil, Label Paper etc.,

PRODUCT PARAMETERS

Printing Size	900mm * 700mm
Print Head	XAAR 1201
Printing Mode	Color, White & Varnish print at same time
Printing Height	0-600mm
Highest Printing Resolution	2400dpi
Printing Color	CMYK + W + V / CMYK + W + CMYK
Software	FlexiPRINT Mini UV Nocai Cloud Edition 19
Dimension (L x W x H)	1940mm * 1790mm * 1540mm
Power Requirement	AC220V±10.50HZ~60HZ
Image Format	Tiff, Jpg, Eps, Pdf, Png, Ai, Psd
Environment	Temperature: 20C-28C, Humidity: 35%-65%
Equipment Weight	400Kg
Ink Type	UV Ink



NC-UL600
UV Printing Machine

Terms and Conditions

1. Payment to be made in QR currency.
2. Payment Terms: As mentioned in Quotation.
3. Bank Details:

Bank Name	Branch	Beneficiary Name	Acc #	Swift Code
Qatar Islamic Bank	Al Khour Branch	Digital Star Qatar	0111453200015	QISB - QAQA
IBAN: QA16QISB000000000111453200015				

4. Bank Charges: Any bank charges relevant to the above transactions will be to your account.
5. Any charges, duties, taxes or levies at the ports of entry will be to our account.
6. The charges of loading, boarding and local conveyance of the technician will be to our account.
7. Any required electrical, mechanical and civil site preparation should be done by the customer according to our engineer's requirements.
8. Digital Star Qatar will not be held responsible for delays caused by any damage in the equipment due to shipment, unloading accidents and any related reasons, which is beyond our control.
9. The warranty will be 12 months from the date of installation from Digital Star Qatar. Wear and tear, consumables are exempted and warranty can be claimed only if you use the Inks and Services from Digital Star Qatar.
10. Service will be free of cost within 12 months from the date of installation.
11. Any claim will be invoice directly to you then we will send for claiming procedure which will take 45-60 days, if the claim got approved credit note will issued directly.
12. Delivery: As mentioned in quotation

DIGITAL STAR QATAR
 ديجيتال ستار قطر

DOHA | QATAR | P O BOX: 47663