

www.digitalstarq.com



FC-500VC

FLATBED CUTTING PLOTTER

- PERFORATION CUT
- KISS CUT
- DIE CUT
- CREASING



Source of Digital Solutions...

Digital Star Qatar has been leading the digital scene in Doha for over 10 years, as suppliers and distributors of signage, advertising and LED solutions. Our commitment to providing the best quality machinery and top-notch technology from around the world has enabled us to set new and improved standards in sign and digital printing industries. DSQ has developed into a true trendsetter and a reliable destination for customers seeking exhaustive custom and wholesale solutions. From sign makers, digital print houses, POS/POP makers, retail fit-out companies, to exhibition stand builders, construction companies and glass and aluminum fabricators industries, we promise to take your business to unprecedented levels



CONTENTS

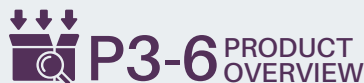

PRODUCT OVERVIEW

The Vulcan FC-500VC flatbed cutting plotter is ideal for light to medium production and design samples. Ideally suited for packaging boxes, tags, cards and labels.

Camera system, User friendly touch screen, Advanced contour cutting, Network interface, U-Disk function and QRcode system, make the FC-500VC special.

Perforation cut, Die cut, Kiss cut and Creasing, make your ideas come true.

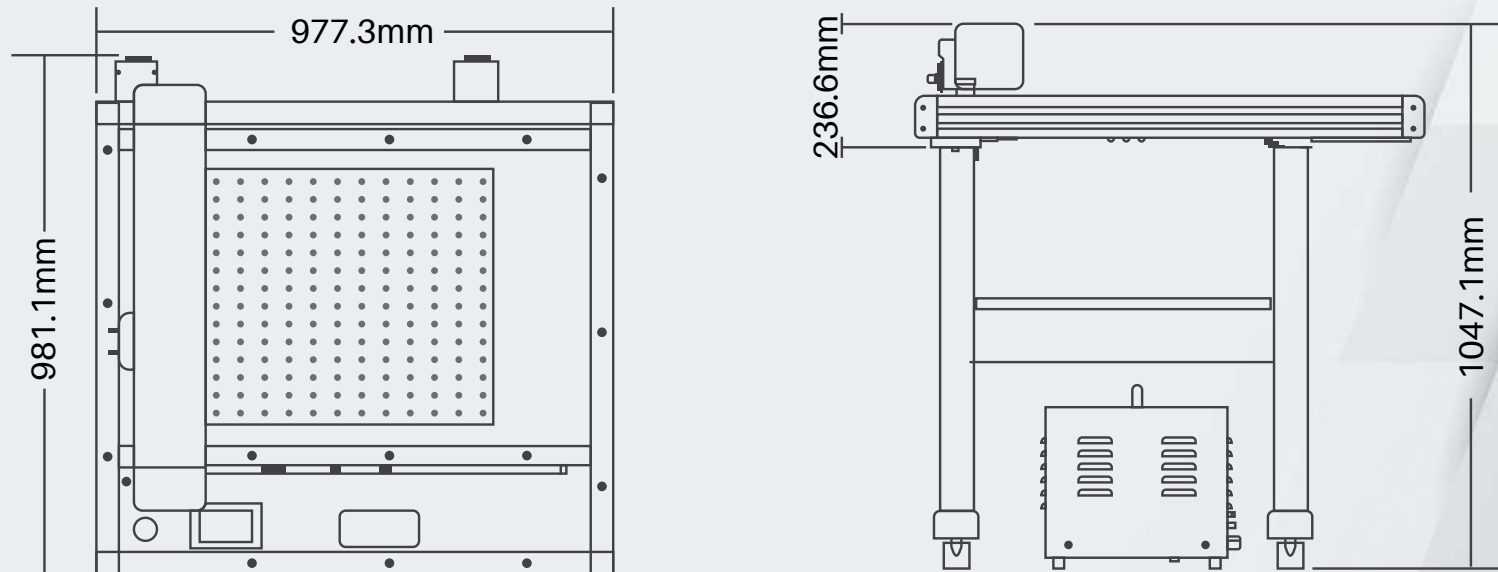

EXTERNAL DIMENSIONS

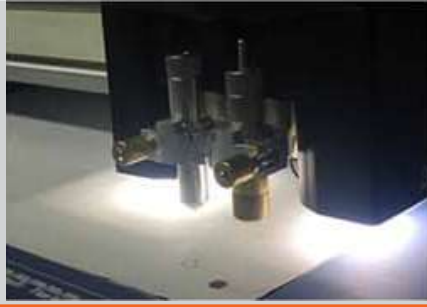

CAMERA SYSTEM

The FC-500VC uses a high resolution camera for accurate detection of registration marks (as small as 5mm) and can reg marks on both colored and transparent materials. The ability to scan small reg marks saves material, thus reducing production costs.

The ability to scan four reg marks within less than 3 seconds saves production time and reduces costs even further



USER FRIENDLY TOUCH SCREN

Easy toggle of vacuum suction: ON-fast/stable hold, OFF -easy replacement of next item.

Easy toggle of arrow key speed for carriage control: Fast(x10)/ Slow(x1)

Single key to set origin or return to origin - guarantees accurate positioning

Re-cut button to instantly repeat last job.

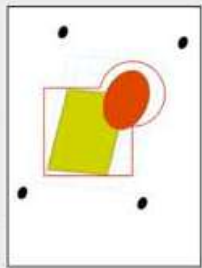

ADVANCED CONTOUR CUTTING

The Vulcan FC-500VC effeciently handles materials loaded on a slant and also compensates for size/ shape distortions. Precise and accurate cuts are assured with our proprietary four mark high-tech detection algorithm.

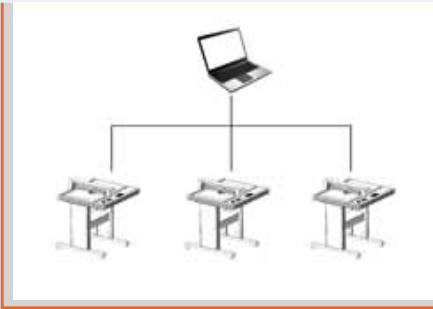

NETWORK INTERFACE

- A) Stable communications over long distance
- B) Control one flatbed cutting plotter from multiple computers
- C) Control different flatbed cutting plotters from one computer



U-DISK FUNCTION

PLT-files saved on USB thumb drives (U-disk) can be used for direct output. this means that the FC-500VC can be used without being connected to a computer.

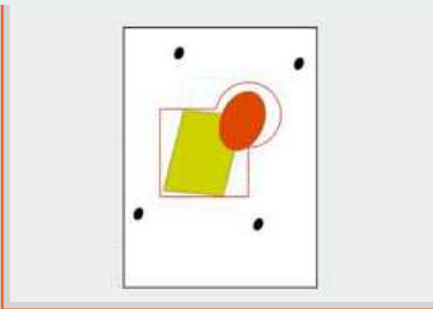

QR CODE SYSTEM

FC-500VC reads QR-codes on the printed media, allowing automatic matching of print and cut files. This both speeds production and eliminates any chance of mismatched files.

SUPPORTED OS



PRODUCT OUTPUT

PACKAGING



TAGS



HOBBIES/CRAFTS



LABELS



PRODUCT SPECIFICATION

Model: FC-500VC

Configuration	Digital servo system, Flatbed
Media hold-down method	Vacuum suction
Maximum cutting speed	700 mm/s (10 to 700 mm/s)
Cutting pressure	Tool1: Max.5.88N(600 gf) Tool 2: Max. 5.88 N (600 gf)
Effective cutting area	495x685mm
Mountable media(Y-axis direction)	640mm
Minimum character size	5 mm square
Mechanical resolution	0.005 mm (5 μ m)
Programmable resolution	HP-GL: 0.025 mm
Repeatability	0.1mm
Standard interfaces	USB2.0 (Full Speed) / U-Disk / Ethernet
Memory	32MB

Command sets	HP-GL
Number of tools	2 tools
Tool types	Cutter blade / Pen / Creasing/Etching tool
Operating screen	4.3-inch touch LCD
Power supply	100 to 240 V AC, 50/60 Hz (Auto switching)
Power consumption	Max. 150VA (machine), Max.550W (vacuum pump)
Operating environment	Temperature: 10 to 35 degrees C (35 to 95 degrees F)
Humidity	35 to 75% RH (non-condensing)
External dimensions	981(Y)x977(X)x1047(H)mm
Packaging dimensions	110X110X58CM (machine) / 44X39X48CM (vacuum pump)
G.W. / N.W.	90kg / 62kg (machine), 25/23kg (vacuum pump)
Compatible OS	Windows and Mac

TERMS AND CONDITIONS

1. Payment to be made in QR currency.
2. Payment Terms: As mentioned in Quotation.
3. Bank Details: -Bank Name: Qatar Islamic Bank
Branch: Al Khour Branch
Beneficiary Name: Digital Star Qatar
Acc #: (0111453200015)
Swift Code: (QISB - QAQA)
IBAN: QA16QISB000000000111453200015.
4. Bank Charges: Any bank charges relevant to the above transactions will be to your Account
5. Any charges, duties, taxes or levies at the ports of entry will be to our account.
6. The charges of lodging, boarding and local conveyance of the technician will be to our account.
7. Any required electrical, mechanical & civil site preparation should be done by the customer according to our engineer's requirements.
8. Digital Star Qatar will not be held responsible for delays caused by any damage in the equipment due to shipment, unloading accidents and any related reasons, which is beyond our control.

9. Warranty will be of 12 months from date of installation from Digital Star Qatar. Wear & tear, consumables are exempted and warranty can be claimed only if you use the service from Digital Star Qatar.
10. Service will be free of cost within 12 months from the date of installation.
11. Any claim will be invoice directly to you then we will send for claiming procedure which will take 45-60 days, if the claim got approved credit note will issued directly.
12. Quotation will be valid for 7 days from here on.
13. Delivery: As mentioned in quotation

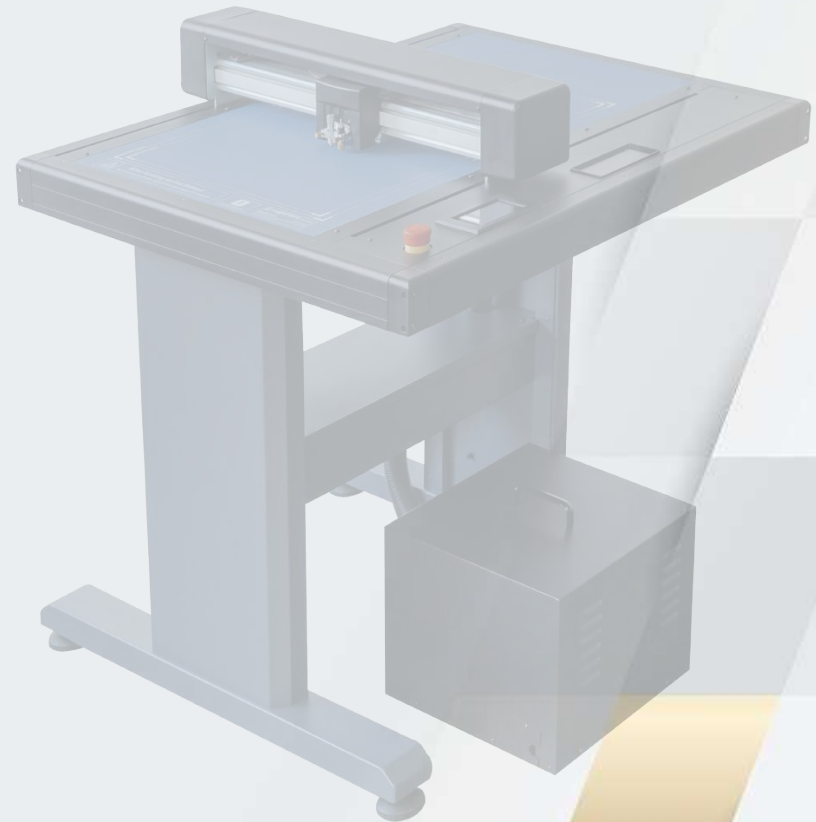



DIGITAL STAR QATAR
ديجيتال ستار قطر

DOHA | QATAR | P O BOX: 47663

 +974 446 02 558  +974 441 63 788  info@digitalstarq.com  www.digitalstarq.com